

WPANT30211-S1A

Body-mount Antenna – 4G LTE Cellular



Application

This rugged and compact 4G LTE Cellular antenna is ideal for applications where high performance and omni-directionality are key. It is also designed to UL57 specifications and comes with a NMO mount connector.

We specialize in developing customized Antenna solutions. Please contact sales@worldproducts.com with your requirements.

Electrical Properties

Operating Frequency	698 – 960 MHz	1710 – 2700 MHz
Approximate Antenna Impedance [Ω]	50 Ω	50 Ω
VSWR (Typical)	< 2:1	< 2:1
Peak Gain [dBi] (Typical)	2.5 to 3 dBi	2 to 4 dBi
Efficiency [%] (Typical)	75 – 85 %	65 – 85%
Polarization	Linear (Vertical)	Linear (Vertical)
Pattern	Omni-directional	Omni-directional

Note: These performance metrics were recorded with the antenna mounted on to a customer supplied access-point chassis.

Mechanical / Environmental Properties

Antenna Dimensions	3.94" Height x 1.65" Dia (100mm x 42mm)
Antenna Color	White
Connector	NMO (Type-N male connector)
Base Gasket	Vinyl siloxane rubber (110-1)
Operating / Storage Temperature	-40°C to +125°C
Shock & Vibration	See Appendix # A
Environmental	See Appendix # A
Hazardous Materials	RoHS Compliant
Packaging	Meets ISTA 2A Standards

Picture



Efficiency [%]

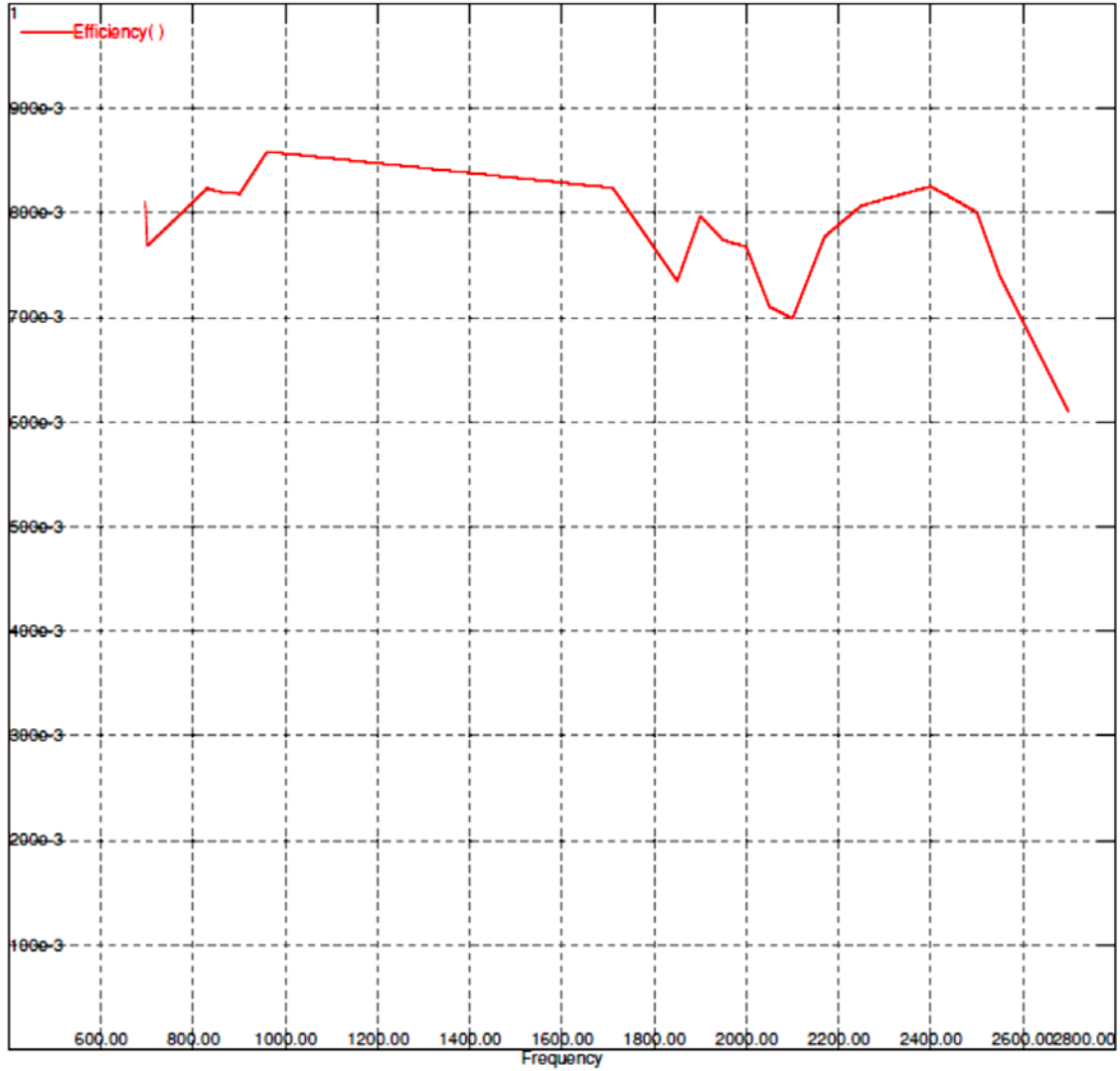

Peak Gain [dBi]

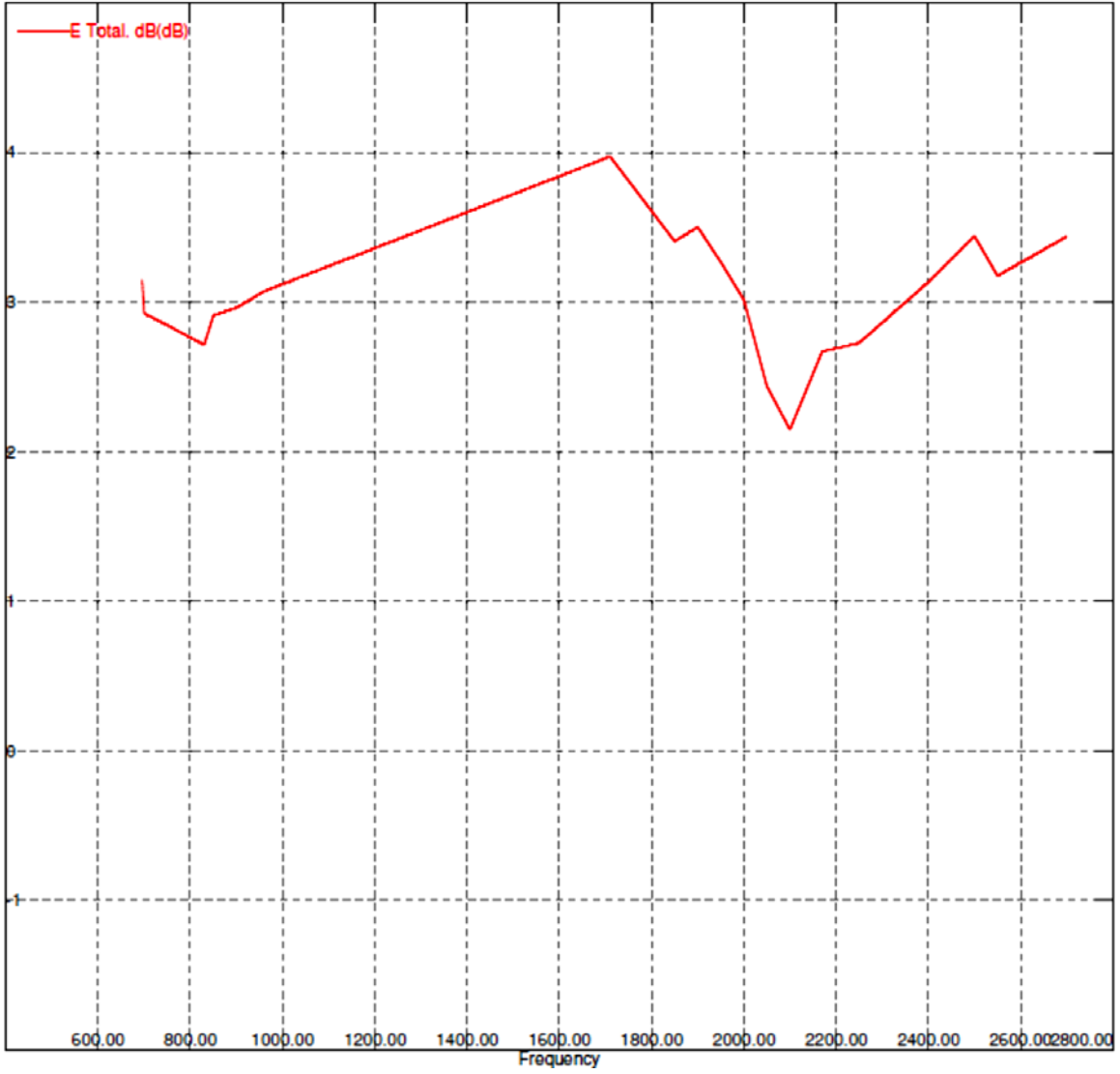

Radiation Pattern – Elevation # 1

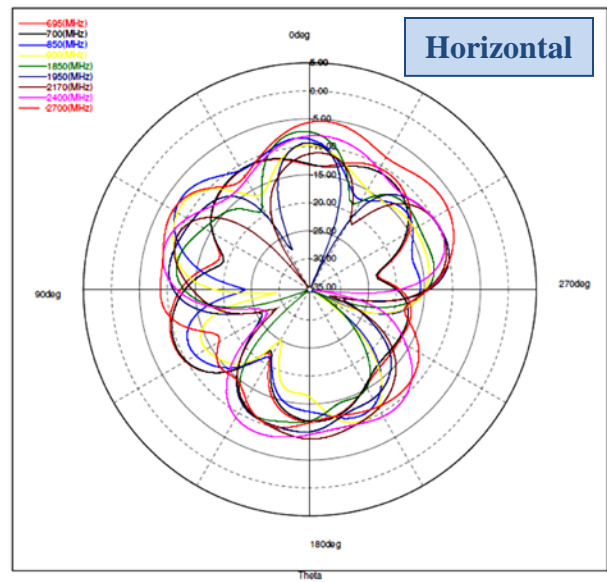
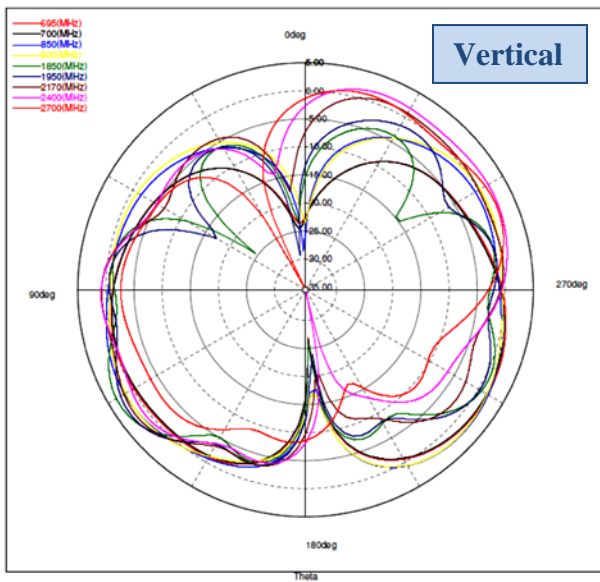
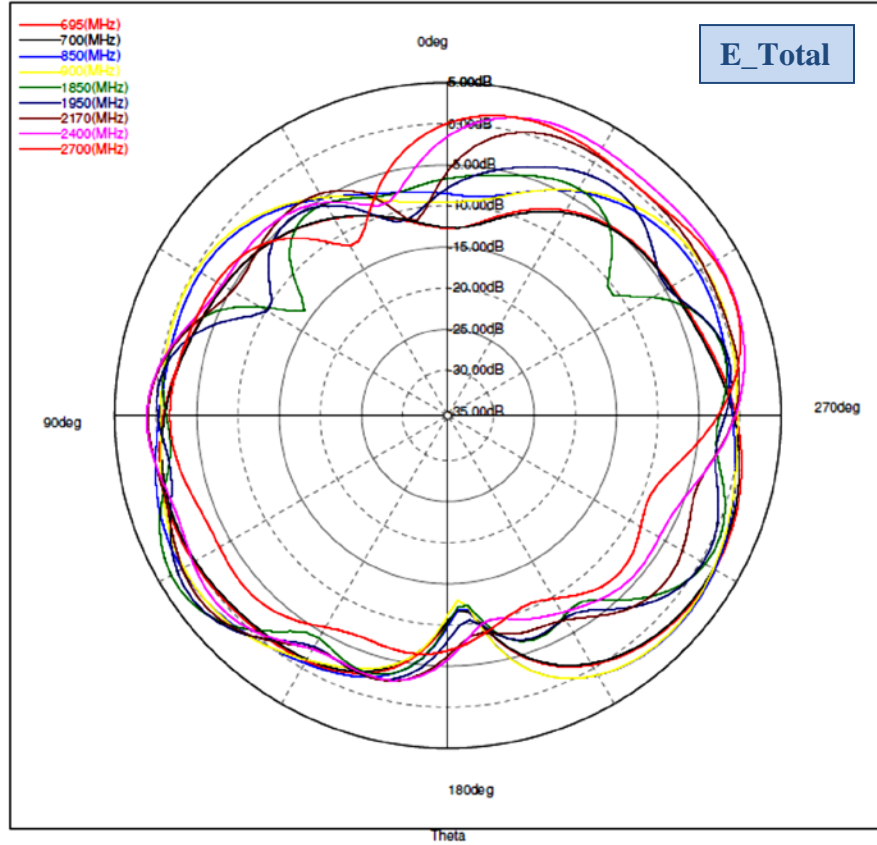

Radiation Pattern – Elevation # 2

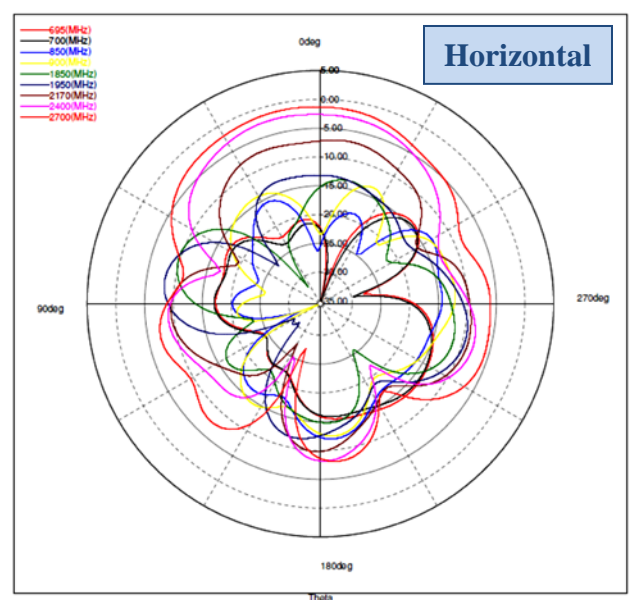
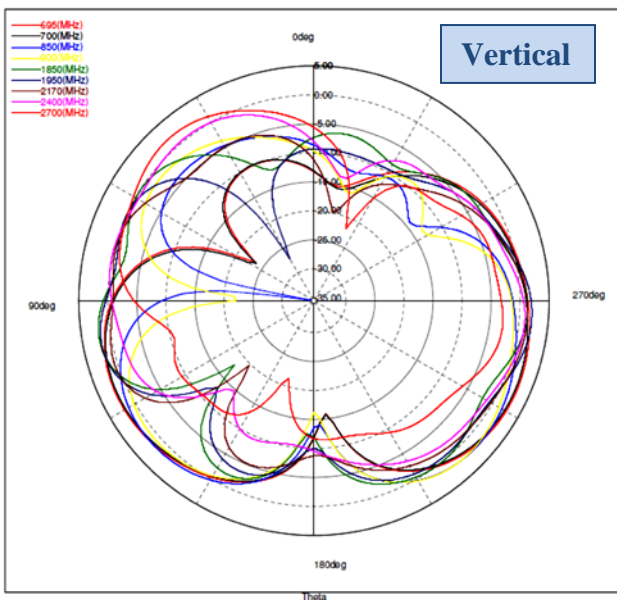
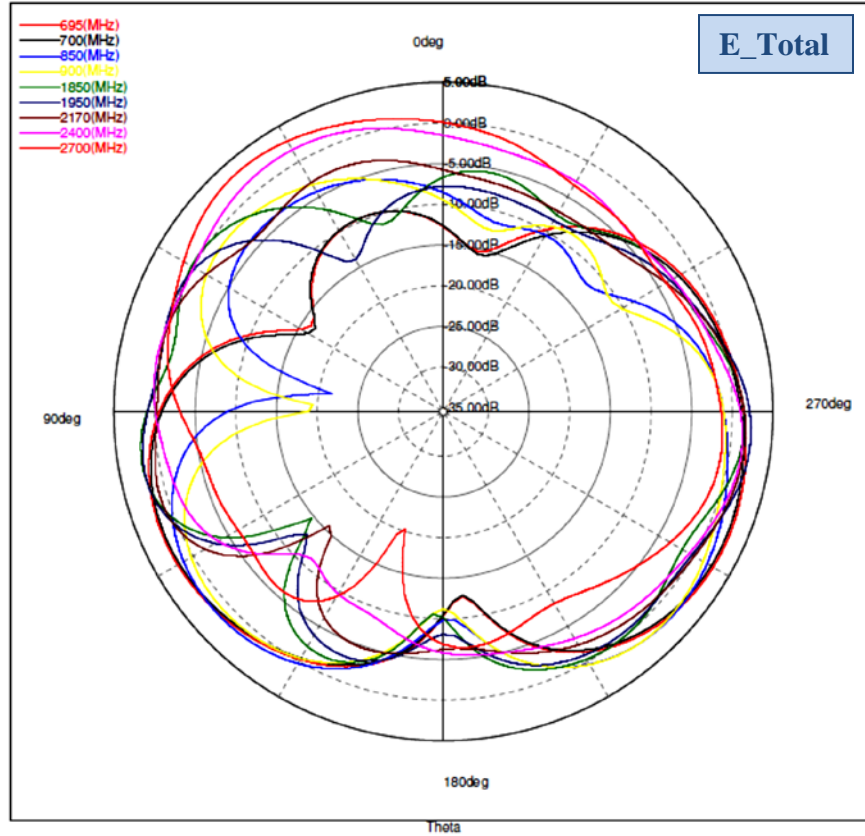

Radiation Pattern – Azimuth

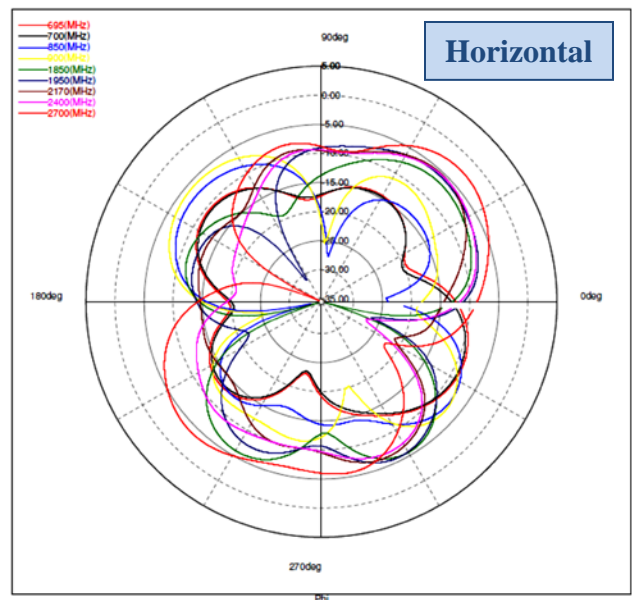
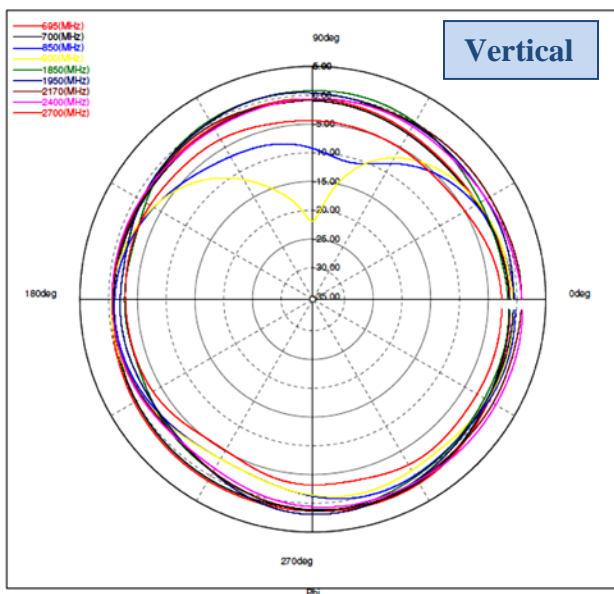
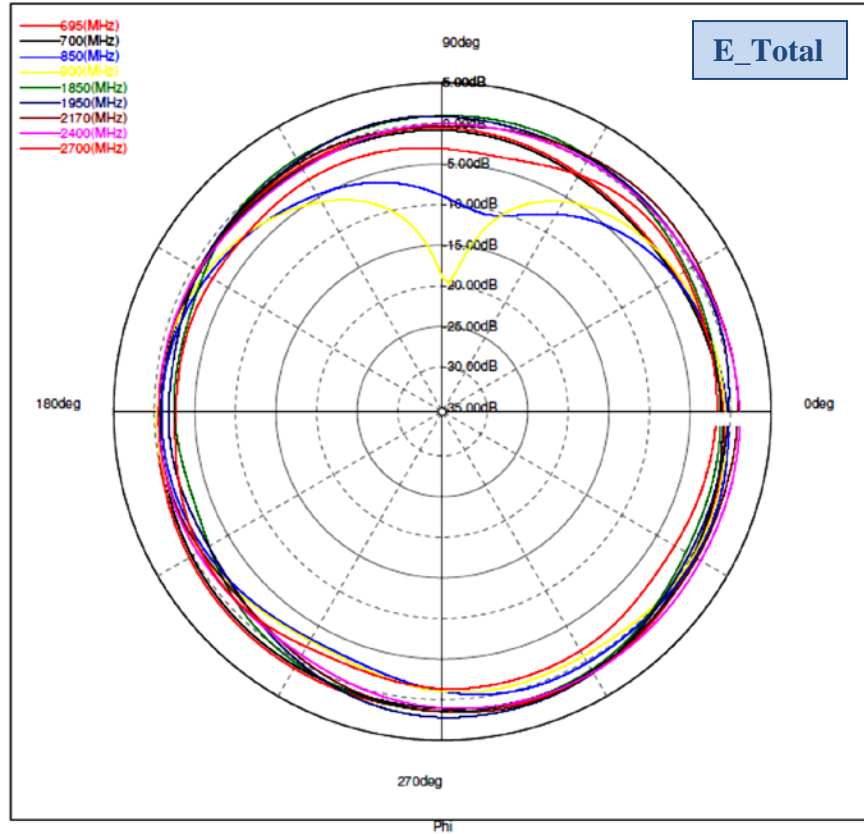

APPENDIX # A: Mechanical, Electrical, Environmental & Shipping Requirements

These below tests will be performed for the First Article Antennas.

Introduction

This test plan covers WPANT30211-S1A WP Wireless Antenna. The types of tests conducted are limited to those traditionally performed during EVT: white box tests which characterize and evaluate electrical, RF, and mechanical performance of specific elements of the entire hardware design under nominal and extreme conditions.

References

Standards

- ANSI C12.1-2001, Specification
- ANSI C12.20-2002, Electricity Meters for 0.2 and 0.5 Accuracy Class
- ANSI C37.63 Standard for Pad-Mounted Line Sectionalizers
- ANSI C37.60 Standard for Circuit Reclosers
- ANSI B109.1, B109.2, B109.3 Gas Displacement Meter standards
- ASTM D822
- ASTM G85 – Modified Slat Fog Spray Testing
- EG-07E, Specification for Approval of Type of Electricity Meters, Instrument Transformers and Auxiliary Devices, Measurement Canada
- FCC Part 15.247
- FCC Part 15, sub-part C
- IEC 60085-2-6
- IEC 60950-1 Safety Standard
- IEC 61000-4-2 ESD
- IEC 61000-4-4 EFT/B
- IEC 61000-4-5 and IEEE 37.90.1 Surge
- IEC 61000-4-6 conducted disturbances from RF fields
- IEC 61000-4-12 oscillatory waves
- IEC 61000-4-16 conducted common mode disturbances
- ISTA Procedure 1A – International Safe Transit Association
- NEMA 250-2003 Enclosure Standards.
- MIL-STD-810F ([DOD Test Method Standard for Environmental Engineering Considerations and Laboratory Tests](#))
- RSS-210 Industry Canada emissions standards.

Client Documents

- SG Hardware Requirements PRD PM-GR001_rev003
- EVT Plan AUS NIC
- Gas IMU PRD Rev. 2 2/12/08

Acronyms

RH	Relative Humidity
Test Tool	Client application used to perform a network operation repetitively
UUT	Unit Under Test
DUT	Device Under Test

Entrance Criteria

Product must have:

- PRD
- Engineering Specification
- Firmware (feature complete, EVT candidate)
- Enclosure (EVT candidate)
- Test support diagnostic tools

Test Matrix

The following table specifies applicable tests; unit quantities, and estimated test duration. Tests and quantities are designated by groups. Tests are divided into groups based on the destructive nature of tests; the ability to run tests in parallel; and the duration of tests.

Test Categories:	WPANT3021 1-S1A Antenna
RF Section	√
Mechanical fit	√
Mechanical connectors	√
Mechanical components	√
Mechanical cables	√
Mechanical enclosures	√
Harsh Environmental Conditions	√
Total Unit Count	10

RF Tests – Electrical Specs Verification

Objective

All the necessary RF tests will be performed on the First Articles and the results will be presented. The test results will show the VSWR, Peak Gain & Efficiency numbers on these Antennas across the frequencies from 698-960 MHz & 1710-2700 MHz.

Expected Result

These First Article Antennas are very consistent in the RF performance and confirm to the specs stated on Page#1. Also, the Peak Gain across all frequencies should be within FCC limits. The Gain numbers should be within control as per regulations in USA & Australia. The variance in Gain should not be more than 1dB across the frequencies in a given band.

RF Tests – VSWR Integrity w.r.t RF Power exposure

The VSWR of First Article Antennas will be tested & recorded. Then these Antennas will be connected to a Signal Generator and will be subjected to 2 Watts of constant input power for duration of 1 hour. The VSWR of these Antennas will be tested again immediately after this 1 hour. Markers on the VNA will be set at 698MHz, 824 MHz, 960 MHz, 1710 MHz & 2700 MHz.

Expected Result

The before & after VSWR's should remain the same. The VSWR values at respective markers should not vary by more than 0.2. This will prove that the Antenna performance is not altered by the input power level or duration.

Mechanical Fit

Tolerances

Objective

Ensure the UUT fits the housing within the specified tolerance. Ensure the UUT mates with other boards with specified tolerances. Ensure the UUT mounting holes are compatible with the screws / snap in posts per the bill of materials. Ensure the UUT fits within the product housing with the tolerances specified on the mechanical drawing for the enclosure.

Setup

Use the shipping version of the housing for the DUT

Steps

Put enclosure together with DUT inside. Confirm that there are no mechanical fit issues and that the DUT is still able to transmit and receive properly.

Expected Result

Clearances

Objective

Ensure the UUT is clear of all obstructions. Historically the DUT has been interfered by the meter wiring; tall capacitors on other boards; proximity of high voltage area (surge resistor, MOV, etc.) to conductive elements (other boards, metallic bridges); through hole leads puncturing capacitors on other boards; relay disconnect meter bases.

Setup

Steps

Expected Result

Mechanical Connectors

Pull force

Objective

Ensure connectors do not disconnect without a “significant” amount of force. This is subject at this point. Certainly, we could employ force activation gauges; however we just need to know that the product will survive ANSI shock / drop / vibe tests. If the product will be deployed in an environment which may have substantial vibration, then perhaps you may wish to go perform shock / drop / vibe at a test lab. This is a judgement call.

Setup

Steps

Expected Result

UV exposure

Objective

Verify components do not become brittle over long term exposure to sunlight.

Setup

Use an outside lab. Duration is dependent on specific test standard / customer.

Steps

Expected Result

Mechanical Components

Torque

Objective

Verify connectors, such as AP power and battery connectors, do not become loose due to “reasonable” torque applied to the connector during cable installation. This can be done either subjectively or objectively with torque gauges.

Setup

Attach a cable to the connector. Cycle a housing with representative assembly from manufacturing over the -40°C to +85°C range. At cold, room, and hot temperatures, attempt to turn the cable (remove).

Steps

Expected Result

The connector should not come loose from the housing.

Mechanical Cables

IP67 Water ingress

Objective

Verify the cable is able to survive IP67 for cables.

Setup

Sample size = 10.

Seal the ends of the cable, or mate them with their opposite gender connector.

Verify the various elements of the cable were assembled by the chosen cable vendor in accordance with the spec sheet using a calibrated torque wrench.

Steps

Dunk the cable into a tube of water at a depth of 1m. Wait 60 seconds. Remove and dry the outside of the cable. Carefully unscrew the various elements of the cable connector and inspect for any water ingress.

Expected Result

The inside cavity should be 100% dry.

Mechanical Enclosures

IP 65/66 hosedown

Objective

Verify the enclosure is impervious to water to the extent required by the enclosure's IP rating.

Setup

For IP 65 (protection against low pressure water jets from any direction), or IP 66 (protection against high pressure water jets from any direction), use an outside lab.

Steps

Expected Result

Drop Test, unpackaged

Objective

Evaluate the product's ability to survive a drop. This tests the PCBA as well as the enclosure.

Setup

The test is performed on concrete surfaces. The heights are 80 cm for concrete.

For all products:

The orientations are: all faces, edges, and corners. A typical box-shaped enclosure will have 6 faces, 8 edges, and 8 corners. Use a different sample for each surface.

Verify the product functionally and mechanically before beginning.

Steps

1. For each height
 - a. For each orientation
 - i. Drop the UUT in its enclosure once.
 - ii. Verify the UUT functions electrically.
 - iii. Do not open the enclosure unless you are certain that unscrewing and re-screwing etc. will not alter subsequent results.
 - iv. If the product fails, stop. Do not proceed with further drops.
 - v. If the product structure is merely weakened (e.g. cracks in the enclosure), continue.

Expected Result

The FSU 2.0 shall continue to function electrically after all drop tests. The enclosure shall remain in tact with no fragments broken off. Hairline cracks measuring less than 1 cm. are acceptable.

Product Packaging

ISTA Testing

Objective

Evaluate the shipping containers that will be used for transporting the product.

ISTA standards are developed for domestic and international transport, for individual shipping containers and palletized product. This test is mainly evaluating the shipping container, but will also test the robustness of the product.

Why ISTA 2A is chosen.

ISTA 2A is the standard for international shipment of individual boxes. We will ship to international customers. We will also manufacture our products outside the USA, so moving them from the factory to the customer site will require international transport.

Products may be palletized in initial shipment from the factory, but shipments will be broken down to smaller batches for installation. RMA shipments will reuse packaging and return in individual shippers. Follow-on orders for replacements, upgrades and network expansions will be smaller and use individual containers.

ISTA 2A test results for an individual container can also be extrapolated to containers on pallets.

Stack height can be calculated and adjusted. Compression Test results can work backwards to determine max stack height. Safety factor can also be adjusted in the compression test calculation.

Setup

The Unit Under Test (UUT) should be verified before the testing.

A Known Good Unit can and should be put in the packaging at the start of the test and remain there during the conditioning phase.

Functionality of the UUT can be verified during the testing, but that is not necessary. Given that this is a transport test and most products are not expected to be functioning during shipping.

Functionality should be verified following the final test step.

Also inspect the UUT for physical damage.

Steps

1. Atmospheric Pre-conditioning
2. Atmospheric Conditioning
 - a. Controlled temperature and humidity.
3. Compression
4. Initial Vibration
 - a. Random vibration to simulate bouncing around in a truck during shipping
 - b. Tri-axial Accelerometer(s) should be placed on the units inside the container.
 - c. Note resonant frequencies during testing
 - d. Random vibration parameters:
 - i. Vibration Intensity = 1.15 G_{rms}
 - ii. Frequency Range = 1-200 Hz
 - iii. Total Duration = 60 min

Orientation	Duration (Min.)
Base	30
Top	10
Side	10
End	10

5. Drop
 - a. 10 drops from a height determined based on the weight of the product(s) in the box. See diagram below.

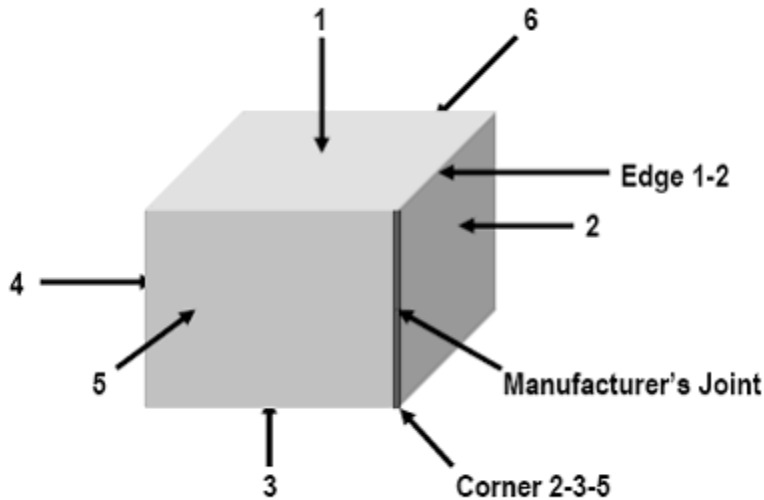

Sequence #	Orientation	Specific face, edge or corner
1	Corner	most fragile face-3 corner, if not known, test 2-3-5
2	Edge	shortest edge radiating from the corner tested
3	Edge	next longest edge radiating from the corner tested
4	Edge	longest edge radiating from the corner tested
5	Face	one of the smallest faces
6	Face	opposite small face
7	Face	one of the medium faces
8	Face	opposite medium face
9	Face	one of the largest faces
10	Face	opposite large face

- b.
- 6. Final Random Vibration
 - a. Repeat procedure from step 4
- 7. Product Evaluation
 - a. Following this last step, open the box and inspect both the packaging material and the product for physical signs of damage.
 - b. Perform a functional verification on the product.

Expected Result

Following the testing, the main criterion is that the product should be fully functional. A secondary concern is how well the packaging holds up. This is important for customer perception as well.

The test lab is generally an expert at packaging systems and running their tests, and even in interpreting the data. But only you can determine if your product is working properly.

Interpreting the data from the testing

1. Drop testing:
 - a. Evaluate the accelerometer readings from the drop test. A rigid box will hold up well in a drop test, but will transfer all the force of the drop to the product inside.
 - b. A soft box will cushion the product, but will look terrible when it arrives at the customer site.
2. Compression test
 - a. Based on the calculated load, did the box pass?
 - b. At what point did it fail?
 - c. Use the fail point and calculate the max stack height.
3. Vibration Test Accelerometer readings
 - a. Did the unit slide around inside the box? Did the packaging hold the product too tightly?

Mechanical Vibration

Objective

Verify CLIENT products (e.g. enclosures, hardware, exposed cables, and connectors) continue to operate after exposure to mechanical vibration as specified in ANSI C12.20-2001 and IEC 60068 Part 2-6.

For APs and Relays, this requirement is not specifically called out in the PRD.

For electricity meters, this test can be skipped if the meter will undergo ANSI C12.20 testing.

Setup

Note: This test must be conducted by a suitably equipped test house.

For APs and Relays, connect the AP/Relay and backup Battery using the provided cable. Also connect AC power to the AP/Relay. All support equipment should be located outside of the area under test. Verify communication with the UUT before starting. Using NetManager under linux / Cygwin, continuously ping the UUT as well as any devices downstream.

For Gas IMUs, this test should be performed before salt spray tests. The intention is to see if the seal between the IMU and meter is affected by vibration. Attach the Gas IMU with battery to the meter.

Steps

For unpackaged vibration, refer to ANSI C12.1-2001 section 4.7.3.20 (which refers to IEC 60068 Part 2-6 for the procedure). The profile shall be a swept sine from 30-350 Hz over 30 minutes for each axis. Sweep time = 1 octave per minute at 5 m/seconds squared (.5 g) along each of three mutually perpendicular axes.

Expected Result

s/eBridge, Gas IMUs, APs and Relays shall be subjected to vibration during operation and shall communicate before, during and after testing.

Electricity meters shall communicate before and after the test per ANSI requirements.

Mechanical Shock

Objective

Verify Client products (e.g. enclosures, hardware, exposed cables, and connectors) continue to operate after exposure to mechanical shock as specified in ANSI C12.20-2001 and/or ANSI B109.1.

Verify Client products function under the conditions specified in ANSI C12.1-2001. This verifies immunity of the enclosure, hardware, exposed cables, and connectors against vibration.

For APs and Relays, this requirement is not specifically called out in the PRD.

For electricity meters, this test can be skipped if the meter will undergo ANSI C12.20 testing.

Setup

Note: This test must be conducted by a suitably equipped test house.

For APs and Relays, connect the AP/Relay and backup Battery using the provided cable. Do not connect AC power to the AP/Relay during the shock. All support equipment should be located outside of the area under test. Verify communication with the UUT before starting. Using NetMgr (or Treset Tool for meters) under linux / Cygwin, continuously ping the UUT as well as any devices downstream.

For Gas IMUs, a steel ball impact test is included here as well as the traditional shock test (reference ANSI B109.1 section 2.10). For the traditional portion of the shock test, the Gas IMU should be tested independent of the actual meter.

Steps

Refer to ANSI C12.1-2001 4.7.3.18 (which refers to IEC 60068-2-27 for the procedure). The profile shall be a half sine pulse, 3 times in each direction for each of the 3 mutually perpendicular axis for a total of 18 shocks per meter. 15 g (150 m/sec squared) peak acceleration for 11 ms with a corresponding velocity change of 1 m/s

For Gas IMUs, drop a 22mm solid steel ball from a height of 15 inches onto the cover.

Expected Result

The UUT shall continuously communicate with both the Net Manager program as well as downstream meters before and after the test. This is an operating test.

Gas IMU housing shall not crack as a result of the steel ball impact.

Harsh Environmental Conditions

Objective

Verify Client products function under the conditions specified in NEMA 250-2003. This verifies protection of the enclosed hardware, exposed cables, and connectors against specific environmental conditions.

For APs and Relays, see SG PRD (R 32). UUTs shall be assembled simulating a field installation, i.e. antenna connected via coax cable, power cable connected, etc. Operation verification shall be established prior to the start of the test and at 250 hour intervals until completion of the test. Cyclic exposure shall be two (2) hours fog and two (2) hours drying.

For FP&L, per their "AMR Scope of Work Feb 08, 2008", APs and electricity meters shall be subjected to a minimum of 1000 hours of salt fog exposure, in accordance with ASTM G85 (Modified Salt Spray (Fog) Testing). Annex A5, dilute electrolyte cyclic fog dry test with the following exceptions; the salt solution was prepared with 0.1% sodium chloride and 0.35% ammonium sulfate. Test specimens are placed in an enclosed chamber, and exposed to a changing climate that comprises of the following 2 part repeating cycle. 2.0 hours exposure to a continuous indirect spray of dilute acidified (pH 5.0 to 5.4) salt water solution, which falls-out on to the specimens at a rate of 1.0 to 2.0 ml/80cm²/hour, in an ambient chamber temperature (21 to 27C). This is followed by 2.0 hours exposure to an air drying (purge) climate, in a chamber temperature of +35C. The number of cycle repeats and therefore the test duration is variable.

The ASTM G85 standard calls for:

In this test cycles of 1hr dry-off and 1hr fog are utilized. The electrolyte is a solution of sodium chloride and ammonium sulfate and is more dilute than the traditional [salt spray fog test](#). The fog portion of this test is conducted at room temperature, the dry-off portion, however, is performed at an elevated temperature. Also the spray atomizing air is not saturated with water for this test.

The electrolyte solution consists of 0.05% sodium chloride and 0.35% ammonium sulfate by mass. The sodium chloride and water are subject to the same purity requirements as for the other test in this specification. The ammonium sulfate shall not contain more than 0.3% total impurities. To obtain complete specifications go to [ASTM International](#).

The temperature throughout the exposure zone during the dry-off phase shall reach and remain constant at 35°C plus or minus 6 1.5°C (95°F plus or minus 3°F) within 3/4-h of switching from the fog period to the dry period.

For electricity meters, this test can be skipped if the meter will undergo ANSI C12.20 testing.

For Gas IMU, these tests reference IMU PRD sections 3.10 and 3.15.

Setup

Note: This test must be conducted by a suitably equipped test house.

For APs and Relays, connect the AP/Relay and backup Battery via the provided cable. Also connect AC power to the AP/Relay. All support equipment (e.g. laptop) should be located outside of the area under test. Verify communication with the UUT before starting. Using netmgr, continuously ping the UUT.

For a Gas IMU, connect the IMU to the Gas meter. If the UUT has a remote mount option, simulate the remote mount option by mounting the remote hardware on a nearby pole with the exact sensor cable installed per our manual.

Steps

Conduct rain tests per NEMA 250-2003.

To ensure the UUT functions on both AC and battery, alternate between AC and DC power. Rain test shall be conducted 30 minutes per side. Conduct salt spray per ASTM method B117-1973 (see above for FP&L deviation).

For the Gas IMU, ANSI B109.1 references ASTM D822 and specifies the following tests to be done sequentially:

1. 1000 cycles wherein each cycle consists of 102 minutes UV, 8 minutes light water spray.
2. A salt spray test is required for 1000 hours in accordance with ASTM method B117-1973 "Salt Spray (Fog) testing".
3. The meter index cover shall be immersed in a typical cleaning agent for 30 minutes.

Expected Result

The UUT shall continuously communicate with both the netmgr program as well as downstream meters before, during and after the test.

There shall not be excessive accumulation of water in the enclosures.

For Gas IMUs, there shall not be any fluid in the IMU, in the cavity between the meter and the IMU, or inside the meter index cover. There shall not be any evidence of electrolytic action, discoloration, rust or corrosion.

Lightning EMP

Objective

Immunity from induced voltages due to nearby lightning strikes: Each device AP, RP, and meter is expected to withstand a lightning strike occurring within close proximity to the equipment under test. The immunity test is a non-industry standard test; however it has been used by Florida Power and Light successfully for many years to identify weaknesses in electronic devices. A sketch of the test setup is shown in Figure 1.

Setup

The tests consist of discharging a negative polarity lightning impulse $1.2\mu\text{s}/50\mu\text{s}$, chopped on front of wave. The surge generator will be discharged into a 3 foot long vertically oriented rod to rod gap. The distance from the gap to the device under test (DUT) will be staged beginning at 15 feet, then moving the gap to 10 feet, then finally to five (5) feet. The gap shall be inline with the antenna. After successfully completing these tests, a direct discharge to the radio antenna will be performed. A field mock up shall be constructed for each device simulating a typical installation. The peak voltage from the generator is expected to be approximately 1.8M volts. Energy discharged will vary with the impulse generator; however FPL's stored energy should be approximately 38k joules.

Steps

The surge generator will be discharged into a 3 foot long vertically oriented rod to rod gap. The distance from the gap to the device under test (DUT) will be staged beginning at 15 feet, then moving the gap to 10 feet, then finally to five (5) feet. After successfully completing these tests, a direct discharge to the radio antenna will be performed.

Expected Result

The UUT shall continuously communicate with SFU before, during and after the test.



WORLD PRODUCTS INC.

19654 Eighth Street East
P.O. Box 517
Sonoma, CA 95476
(707) 996.5201
www.worldproducts.com
sales@worldproducts.com

APPROVALS

Customer

Approval Signature: _____

Name: _____

Title: _____

Approval Date: _____

World Products Inc.

Approval Signature: _____

Name: _____

Title: _____

Approval Date: _____