

DC HIGH VOLTAGE EV CONTACTOR

EVC100



▶ FEATURES

- With ceramic seal structure, the contact chamber filled with hydrogen mixed educing gas, combined with magnetic blow-out. Voltage relay can cut off load voltage of 1000VDC.
- The outer coil energy saving plate has a low holding power of 1.5W and a coil induction electromotive force of 0.
- The model with auxiliary contact can monitor the position of the main contact in real time, and is suitable for the charging product field where the main contact is required to be monitored in real time.
- The main / auxiliary contacts in a sealed, hydrogen mixed reduced gas environment are not easily contaminated or oxidized even in the harshest environments.products have been approved by CCC, CQC, CE, CB and passed the TS16949 system.

▶ COIL SPECIFICATION

ITEM		MAX.STARTING CURRENT(A)	MAX.IMPACT TIME(ms)	NOMINAL OPERATING CURRENT(A)	PULL-IN VOLTAGE (V)	DROP-OUT VOLTAGE(V)	COIL POWER	MAX. ALLOWABLE VOLTAGE(V)
NOMINAL VOLTAGE								
DC	9~36	1.5A	120ms	0.12A@12VDC 0.06A@24VDC	≤9VDC	≥3VDC	18W (0.1s) Keep 1.7W	36VDC
	12 V	0.46A	Keep	0.46A	≤9VDC	≥1VDC	5.5W	16VDC
	24 V	0.25A	Keep	0.25A	≤18VDC	≥2VDC	6W	32VDC

▶ CONTACT RATINGS

ITEM	MODEL	Unipolar resistive load(L/R≤1ms)	
		EVC100	
Maximum Continuous Current		100A	
Maximum Cut Off		V	1000V DC
		A	1000A 300VDC 1 Ops
Min. Switching Capacity(Resistive Load)		1A 12VDC	
Short Term Current		200A 90s, 300A 30s, 1000A 0.6s	
Contact Resistance		≤ 1.5mΩ (DC 100A)	
Contact Material		Alloy Cu	
Contact Arrangement		1 A (SPST-NO.)	
General Auxiliary Contacts Current Range		2A 30VDC / 3A 125VAC	
General Minimum Current Auxiliary Contacts		100mA 8VDC	

▶ PART NUMBERING RULE

EVC 100 A - 1 A D

Series	Rated Current	Auxiliary contactor	Contact Type	Coil Voltage	Coil lead
EVC=Circular type	100:100A	Null:no auxiliary contactor	1: 1a Normally Open	12: 12VDC	D=direct wire without connection plug
		A:With auxiliary contactor		24:24VDC	E=direct wire with connector plug
				A:9~36VDC	

- Note: 1. specifications are obtained in the environment of 23 degrees C
 2. maximum allowable contact temperature: 150 C; 175 degrees C 2Hmax; 200 degrees C 2minMax
 3. the finished product withstand pressure / insulation is 50Mohm,
 4.after the maximum limit cut-off, the auxiliary contacts can not meet the pressure insulation
 5. coil resistance test error + 10%

DC HIGH VOLTAGE EV CONTACTOR

EVC100



INSULATION PERFORMANCE

Insulation Resistance		Min.1000MΩ 1000V DC
Dielectric Strength	Between Open Contacts	2500V AC 60 Sec.1mA
	Between Contact And Coil	2500V AC 60 Sec.1mA
Operate Time(at 20 °C)		≤30ms
Release Time(at 20 °C)		≤10ms

MECHANICAL PARAMETERS

Life	Mechanical Life		2x10 ⁵ Ops
	Electrical Life (Resistive Load) (L/R≤1ms)	450V DC 100A	6,000 Ops
		750V DC 100A	1,000 Ops
Shock Resistance	Functional		Min 196% {20G} 11ms ,(10μs)
	Destructive		Min 490% {50G} 6ms
Vibration Resistance	Functional		49% {5G} 10 to 200Hz,(10μs)
	Destructive		49% {5G} 10 to 200Hz 4h
Conditions For Operation, Transport And Storage	Ambient Temperature		-40°C to +85°C
	Humidity		5 to 95% R.H.
Weight			180g

ENGINEERING DATA

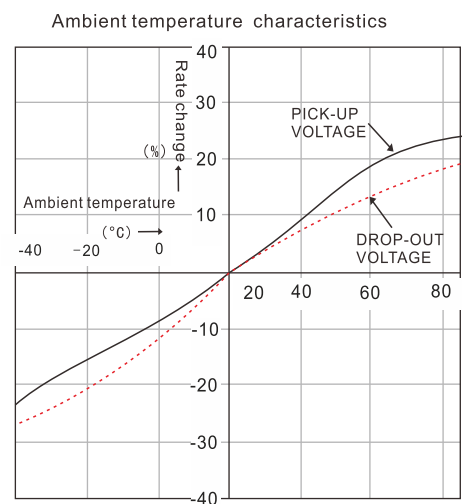
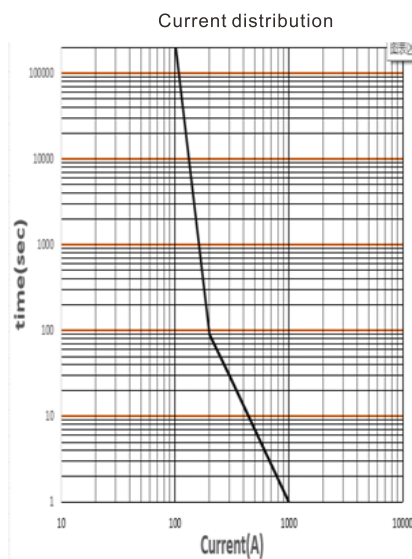
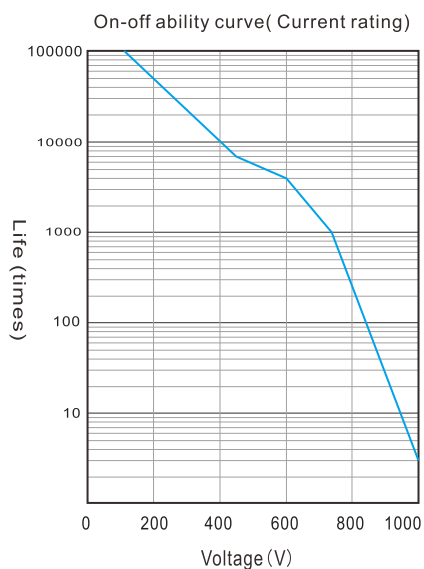

DC HIGH VOLTAGE EV CONTACTOR

EVC100



▶ DIMENSIONAL DRAWING 1

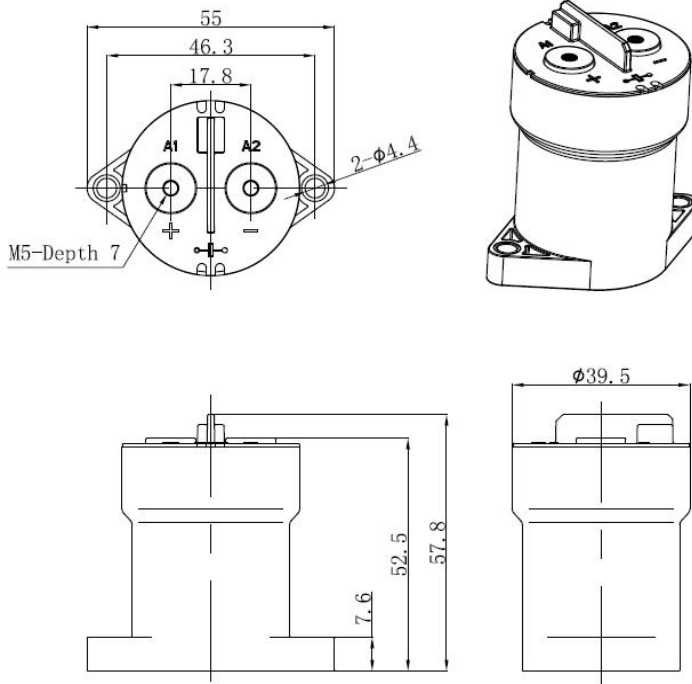

▶ SCHEMATIC

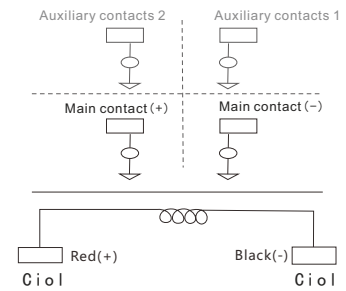

▶ DIMENSIONAL DRAWING 2

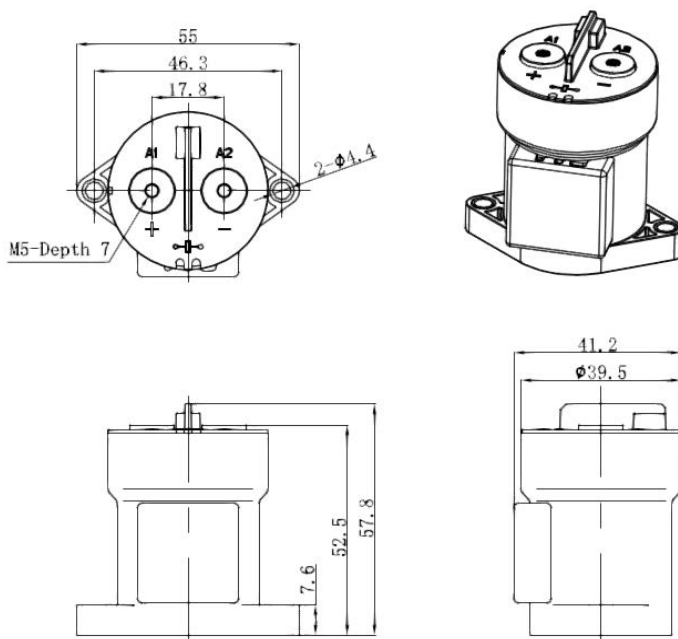

▶ MOUNTING DIMENSIONS

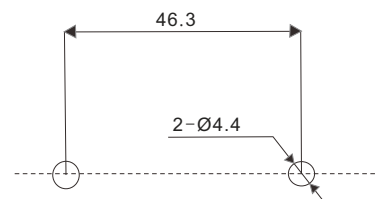

Tolerance:
dim<10mm:±0.3;
dim=10~50mm:±0.6;
dim>50mm:±1.0

EV RELAY APPLICATION PRECAUTIONS:

EV series high voltage DC relay with higher arc cooling capacity hydrogen medium, have the ability of DC high voltage cutting and adopt ceramic sealing explosion-proof structure. Contact part have waterproof, anti oxidation and other functions. It can be widely used in electric vehicles, hybrid vehicles, fuel cell vehicles, construction machinery, photovoltaic power generation, wind power generation, battery charging and discharging system, DC voltage power control and other DC high voltage fields.

Notes:

- 1.All types of relay terminals have polarity difference. Please use correctly according to the mark on each surface of the product. When the connection polarity is reversed, the electrical characteristics promised in the specification will not be guaranteed.
- 2.The rated value of contact parameters are the value of resistive load. Without measures, there may be a decline in electrical life and the occurrence of cut off. If using diodes, it may lead to a decline in cutting performance
- 3.During the action voltage test of double coil relay, voltage can not be risen slowly. Please drive the product coil through the fast rising (step type power supply mode) , otherwise the relay will not act.
- 4.Don't put the relay in the environment that over normal operating temperature (-40 degrees C to 85 C) for a long time.
- 5.Please avoid installing near in strong magnetic field (around transformer and magnet) and hot objects.
- 6.Make sure the main power line is closest to the relay leading-out terminal, then installed tightly according to the order of the flat washer, spring washer and nut. Incorrect connection order may cause serious overheating, and lead to the insulation layer melting of connecting cable .
- 7.Screw locking torque of every part should be accordant with following chart in case of breakage.

▶ Part I Leading-out terminal installation:

Nut	EVR20	EVR40	EVR100	EVR120	EVR150	EVR200	EVR250	EVR300	EVC50	EVC100	EVC135	EVC150	EVC 200 EVC250	EVC300 EVC350	EVC400 EVC500
M4		3N.m~4N.m							3N.m~4N.m	3N.m~4N.m	3N.m~4N.m				
M5			6N.m~8N.m	6N.m~8N.m	6N.m~8N.m										
M6						10N.m~12N.m	10N.m~12N.m	10N.m~12N.m				10N.m~12N.m	10N.m~12N.m	10N.m~12N.m	10N.m~12N.m
M8															

Remarks:EVC050,EVC100 Use screws;

▶ Part II Relay installation:

Screws	EVR20	EVR40	EVR100	EVR120	EVR150	EVR200	EVR250	EVR300	EVC50	EVC100	EVC135	EVC150	EVC200 EVC250	EVC300	EVC350	EVC400	EVC500
M4									2N.m~3N.m	2N.m~3N.m	2N.m~3N.m						
M5	3N.m~4N.m	3N.m~4N.m	3N.m~4N.m	3N.m~4N.m	3N.m~4N.m	3N.m~4N.m						3N.m~4N.m	3N.m~4N.m	3N.m~4N.m	3N.m~4N.m	3N.m~4N.m	3N.m~4N.m
M6	5N.m~6N.m	5N.m~6N.m	5N.m~6N.m	5N.m~6N.m	5N.m~6N.m	5N.m~6N.m	5N.m~6N.m	5N.m~6N.m				5N.m~6N.m	5N.m~6N.m	5N.m~6N.m	5N.m~6N.m	5N.m~6N.m	5N.m~6N.m
M8																	

Remarks: a. Screw strength must be in compliance with the requirements of grade 8.8 or above ; (GB/T70.1)
b. The effective locking thread length must be greater than 5mm;

8. Please avoid adhering grease and other foreign material on the leading-out terminal; Please use the following specifications of the connection wire, otherwise it may cause abnormal heat of the terminal part.

Product	EVT150	EVR20	EVR40	EVR100	EVR120	EVR150	EVR200 EVC 200	EVR250	EVR300	EVC50	EVC100	EVC135	EVC150	EVC250	EVC300	EVC350	EVC400	EVC500
Nominal sectional area (Min)	50mm ²	4mm ²	15mm ²	35mm ²	50mm ²	75mm ²	100mm ²	120mm ²	150mm ²	13mm ²	35mm ²	40mm ²	75mm ²	120mm ²	150mm ²	200mm ²	200mm ²	300mm ²

9.Packing specification

Each box	EVT150	EVR20	EVR40	EVR100	EVR120	EVR150	EVR200	EVR250	EVR300	EVC50	EVC100	EVC135	EVC150	EVC 200 EVC250	EVC300	EVC350	EVC400	EVC500
Specifications D*W*H	475*328 *113mm	362*357 *146mm	407*337 *131mm	482*457 *91mm	482*457 *91mm	532*432 *91mm	557*577 *96mm	557*577 *96mm	507*402 *119mm	412*407 *146mm	412*407 *146mm	412*407 *146mm	482*382 *106mm	482*382 *106mm	507*402 *119mm	507*402 *119mm	507*402 *119mm	507*402 *119mm
Number	40pcs	40pcs	40pcs	20pcs	20pcs	20pcs	20pcs	20pcs	15pcs	60pcs	60pcs	60pcs	20pcs	20pcs	20pcs	20pcs	20pcs	20pcs
Net weight	5.4kg	6.4kg	7.2kg	7kg	7kg	8kg	9.4kg	9.4kg	8kg	10.8kg	10.8kg	10.8kg	7.6kg	7.6kg	11kg	11kg	11kg	11kg
Monomer	0.13kg	0.16kg	0.18kg	0.35kg	0.35kg	0.4kg	0.47kg	0.47kg	0.53kg	0.18kg	0.18kg	0.18kg	0.38kg	0.38kg	0.55kg	0.55kg	0.55kg	0.55kg

Note: there is a shockproof bubble bag in the packing box, and there is shockproof foam inside the box;

- 10.In the case of accidental fall of the relay, see intended not to use.
- 11.Attentions and product technical data should be updated termly, and copyright by Ebusbar all.